

LINSEIS

pushing boundaries



**MEGA
LAB**

Tel. 2310855844, 2106452848

Email. contact@megalab.gr

www.megalab.gr

LFA L51

Light
**Flash
Analysis**



WWW.LINSEIS.COM



Since 1957 LINSEIS Corporation has been delivering outstanding service, know-how and leading innovative products in the field of thermal analysis and thermo-physical properties.

Customer satisfaction, innovation, flexibility, and high quality are what LINSEIS represents. Thanks to these fundamentals, our company enjoys an exceptional reputation among the leading scientific and industrial organizations. LINSEIS has been offering highly innovative benchmark products for many years.

The LINSEIS business unit of thermal analysis is involved in the complete range of thermoanalytical equipment for R&D as well as quality control. We support applications in sectors such as polymers, chemical industry, inorganic building materials, and environmental analytics. In addition, thermophysical properties of solids, liquids, and melts can be analyzed.

Rooted in a strong family tradition, LINSEIS is proudly steered into its third generation, maintaining its core values and commitment to excellence, which have been passed down through the family leadership. This generational continuity strengthens our dedication to innovation and quality, embodying the essence of a true family-run business.

LINSEIS provides technological leadership. We develop and manufacture thermoanalytic and thermophysical testing equipment to the highest standards and precision. Due to our innovative drive and precision, we are a leading manufacturer of thermal analysis equipment.

The development of thermoanalytical testing machines requires significant research and a high degree of precision. LINSEIS Corp. invests in this research to the benefit of our customers.

C L A U S L I N S E I S
C E O D I P L . P H Y S .

To strive for the best due diligence and accountability is part of our DNA. Our history is affected by German engineering and strict quality control.

We want to deliver the latest and best technology for our customers. LINSEIS continues to innovate and enhance our existing thermal analyzers. Our goal is to constantly develop new technologies to enable continued discovery in Science.

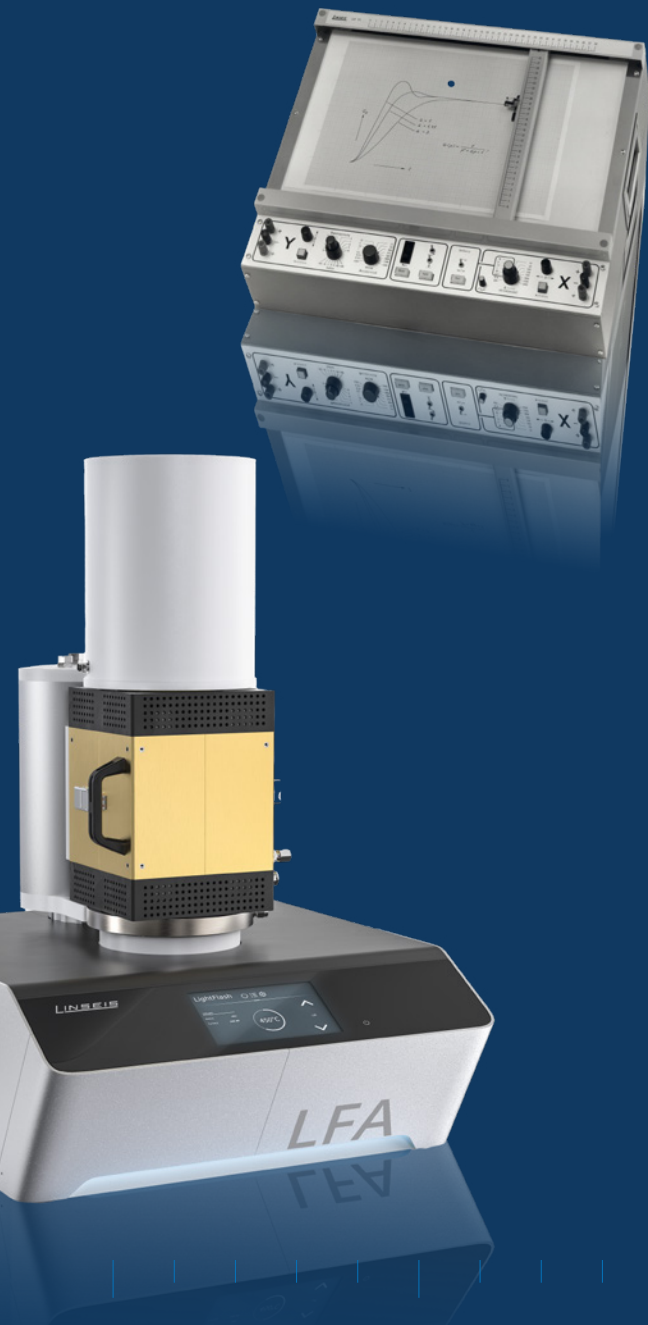

Engineering & Innovation

Light Flash Analysis

Information about the thermophysical properties of materials and heat transfer optimization of final products is becoming more and more vital for industrial applications. Over the past few decades, the flash method has developed into a commonly used technique for the measurement of the thermal diffusivity and thermal conductivity of various kinds of solids, powders, pastes and liquids. Application areas are electronic packaging, heat sinks, brackets, reactor cooling, heat exchangers, thermal insulators and many others. Trouble-free sample preparation, small required sample dimensions, fast measurement times and high accuracy are only a few of the advantages of this non-contact and non-destructive measurement technique.

LINSEIS offers a variety of instruments to measure the Thermal Diffusivity/Conductivity. The LFA L51 Light Flash series provides a cost effective solution for the temperature range from $-100\text{ }^{\circ}\text{C}$ up to $1250\text{ }^{\circ}\text{C}$.

- **ABSOLUTE METHOD:** Absolute thermal diffusivity measurement, no calibration, meets ASTM and DIN standards such as ASTM E-1461, DIN EN 821-2 and DIN 30905.
- **DETECTORS:** InSb (LN_2 or Peltier cooled) or MCT (LN_2 cooled). User-exchangeable, optional automatic LN_2 refilling.
- **ENVIRONMENTAL OPTIONS:** Vacuum or various gas atmospheres possible with optional gas dosing system.

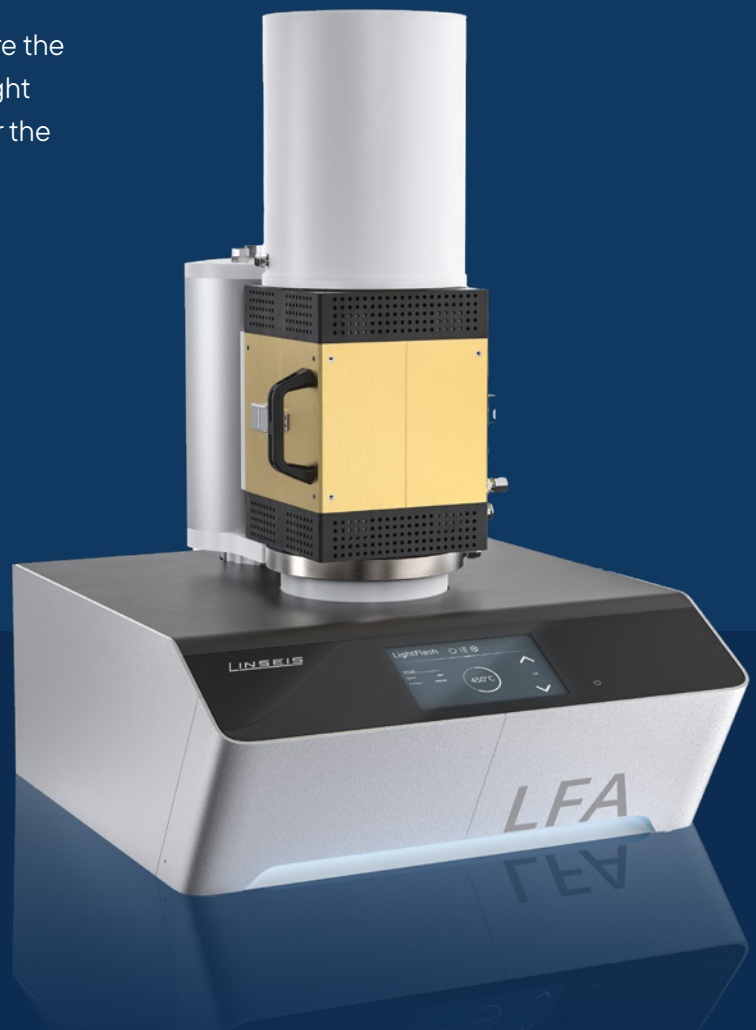

Measurement Concept

The sample is either positioned on a sample robot, which is surrounded by a furnace (LFA L51 LT/500/1000) or within one out of five microheaters located on a moveable linear stage (LFA L51 1250). For the measurement, the furnace is held at a predetermined temperature and a programmable energy pulse irradiates the rear side of the sample, resulting in a temperature rise at the sample surface. This resulting temperature rise of the surface of the sample is measured by a very sensitive high speed infrared (IR) detector. Both, thermal diffusivity and specific heat can be determined from the temperature vs. time data. If the density (ρ) is identified, the thermal conductivity can be calculated via:

$$\lambda(T) = \alpha(T) \cdot C_p(T) \cdot \rho(T)$$

λ =Thermal Conductivity [W/m·K]
 α =Thermal Diffusivity [mm²/s]
 C_p =Specific Heat [J/g·K]
 ρ =Density [g/cm³]
 T =Temperature

Principle of LFA L51 measurement

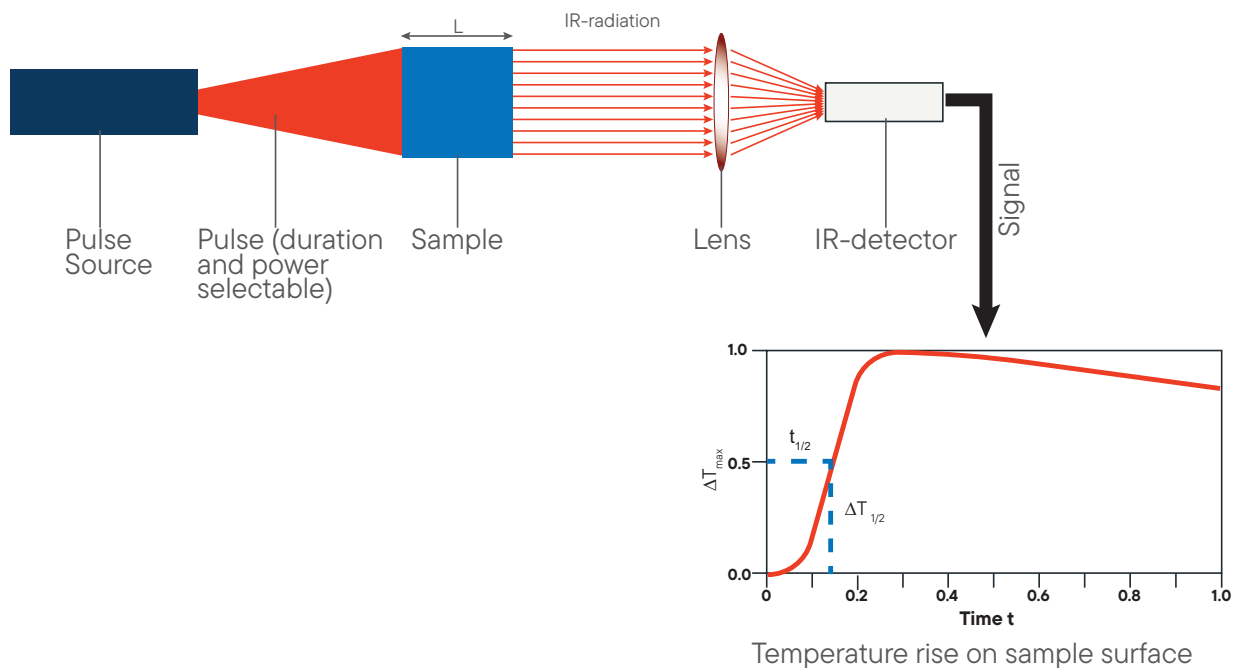

Calculation of thermal diffusivity

- Determine the baseline and maximum rise to give the temperature difference, ΔT_{max}
- Determine the time required from the initiation of the pulse for the rear face temperature to reach $\Delta T_{1/2}$. This is the half time, $t_{1/2}$.
- Calculate the thermal diffusivity, α , from the specimen thickness L and the half-time $t_{1/2}$, as follows:

$$\alpha = 0.13879 \cdot \frac{L^2}{t_{1/2}}$$

L=Sample height [mm]
 $t_{1/2}$ =Half time rise [s]
 α =Thermal Diffusivity [mm²/s]

Applies to an optimal system. In practice, models optimized for application evaluation are used, see page 22.

System Design

The vertical arrangement of the Linseis **LFA L51 LT/500/1000**, with the detector on top, the sample in the middle, and the Pulse Source with light guiding system at the bottom, ensures easy handling and delivers the best possible measurement results. This flexible design allows easy sample loading, a high sample throughput as well as measurement capabilities to analyse also demanding samples such as thin films, powders and materials with ultra-low thermal conductivity.

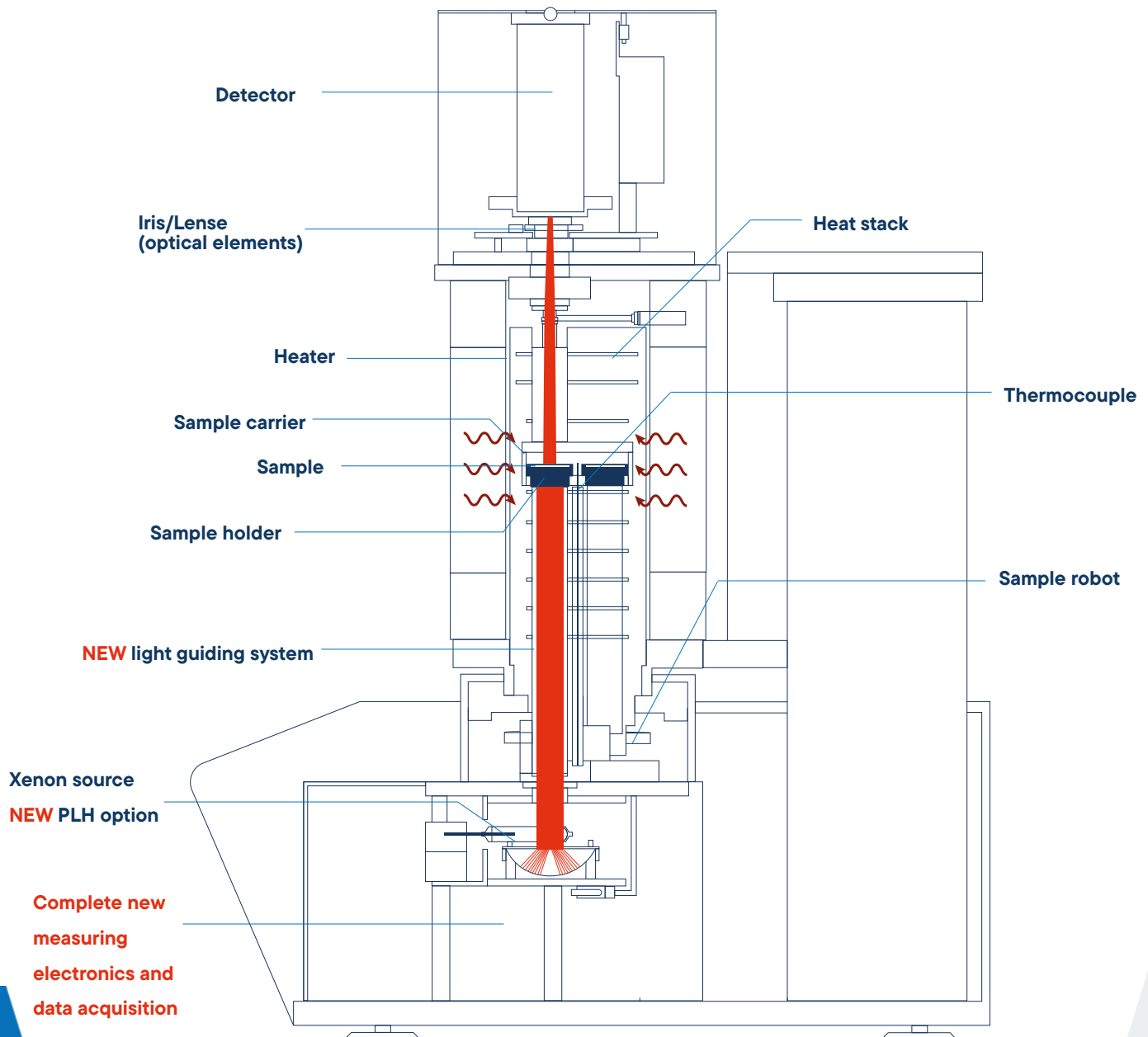

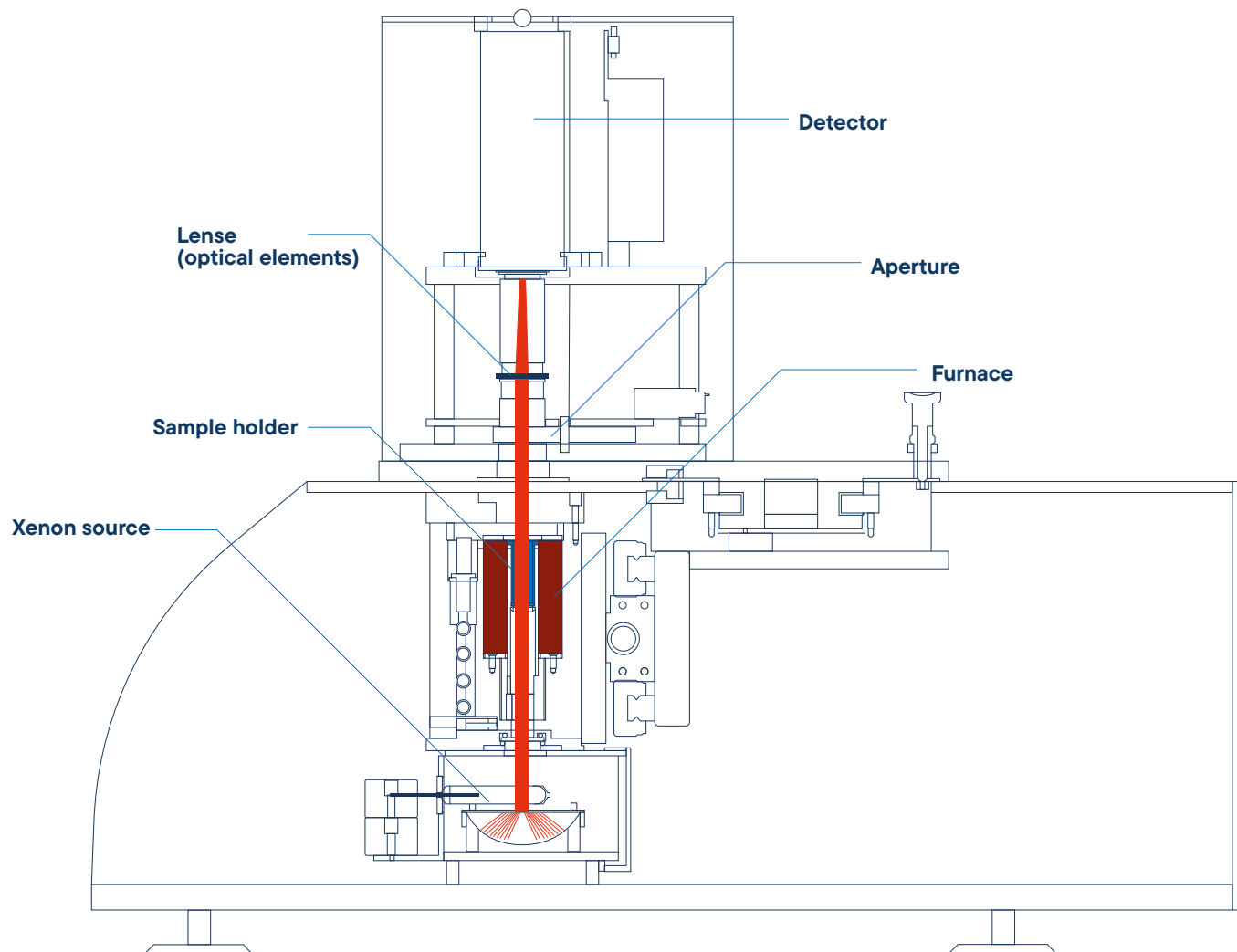

The Linseis **LFA L51 1250** features a vertical configuration with the detector positioned above the sample and the Light Flash source below. This design facilitates straightforward handling and optimal measurement outcomes. The five micro-heaters heat ultra-fast, which minimizes the total measuring time and increases the throughput.

LFA L51 Vision Control

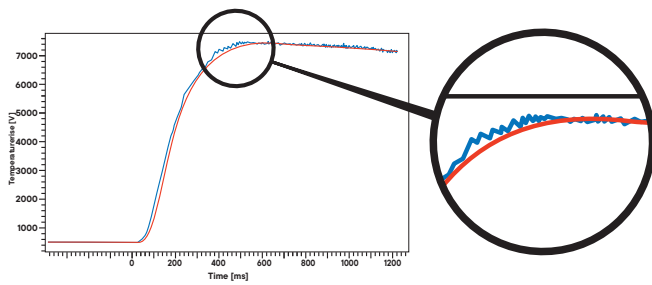

large diameter

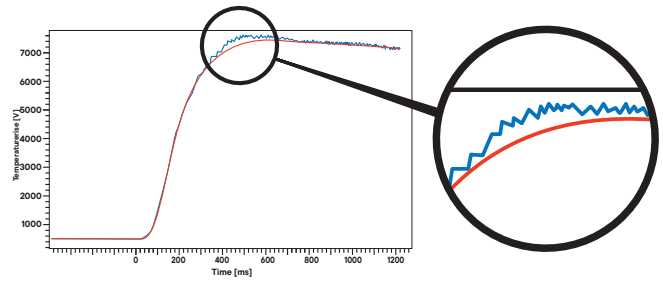

small diameter

Measurement principle

In a Flash system the signal quality depends on the amount of radiation of the sample which hits the surface of the infrared detector. Normally, the active surface of the detector is limited (e.g. 2x2 mm²) compared to a sample diameter of (3 mm to 25.4 mm). For this reason, an optimized arrangement of IR-detector, lens and sample is used to improve the imaged sample surface. The measurement spot on the sample should be as large as possible, but it should not exceed the sample. Any exceeding of the spot can generate measurement artefacts or additional noise on the signal. The vision control feature provides best signal quality for any sample dimension. The optimization ensures superior signal quality for big and small samples.

Vision Control

The „vision control“ option ensures a perfect detection spot for different sample geometries. This allows the perfect adaption to image the sample surface ideally and sharply on the sensor active area.*

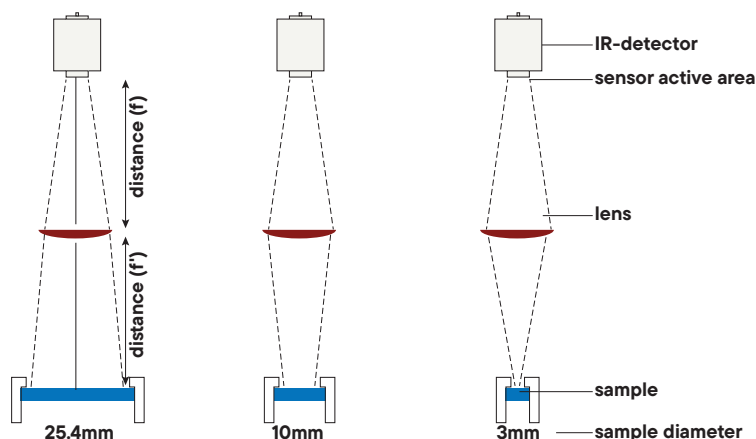

*Not available in all configurations and countries

Periodic Laser Heating Option



The L51 LFA instruments can be upgraded with the PLH (periodic laser heating) option. This patented 2-in-1 solution provides two measurement techniques in one instrument, maximizing the range of applications and enabling analysis of samples ranging from μm to mm thickness.

The PLH technology has been specifically developed and optimized to characterize thin film samples with unparalleled accuracy. It covers a measurement range of sample thicknesses from $10\ \mu\text{m}$ to $500\ \mu\text{m}$ and a thermal diffusivity range spanning from 0.01 to $2000\ \text{mm}^2/\text{s}$.

The PLH L53 option can handle a wide variety of materials, making it suitable for:

- Heat spreader materials such as graphite foils and thin copper foils,
- Semiconductors with complex thermal properties,
- Metals requiring precise diffusivity measurements,
- Ceramics and polymers used in advanced material systems

Anisotropy and inhomogeneity analysis

With its advanced mapping capabilities, the PLH system enables the spatially resolved measurement of thermal diffusivity across a sample. This feature is particularly valuable for identifying anisotropies (directional differences in thermal behavior) and inhomogeneities (material inconsistencies). By scanning multiple regions, users gain a comprehensive understanding of the thermal properties of thin films, ensuring optimized material performance for demanding applications.

Applications and Industry Focus

Typical applications include the analysis of freestanding films and membranes, which are of increasing importance in the battery and hydrogen industries. The ability to accurately measure thermal transport properties in these materials is crucial for improving energy efficiency, thermal management, and overall system performance.

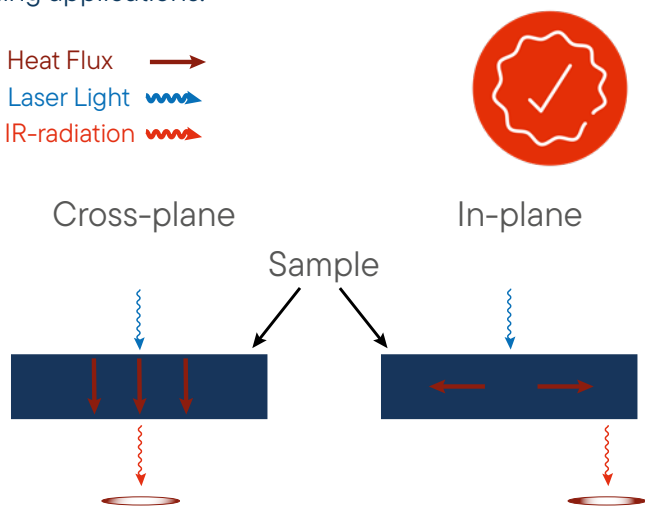

Key Features at a Glance

- **Anisotropy analysis:** Combines cross-plane and in-plane measurements seamlessly.
- **Versatile material compatibility:** Suitable for semiconductors, metals, ceramics, and polymers.
- **Mapping capability:** Allows precise spatial analysis of anisotropies and inhomogeneities within the sample.
- **High measurement accuracy:** Covers a broad range of sample thicknesses and thermal diffusivity values.

High speed infrared furnace or micro-heater for unmatched sample throughput



The LFA 51 device can be equipped with either a high-speed infrared furnace (LFA L51 500/1000), an advanced micro-heater (LFA L51 1250) or an low temperature resistance furnace (LFA L51 LT), allowing for exceptionally fast heating and cooling rates. This rapid temperature adjustment minimizes downtime, saving valuable time and enabling a high sample throughput for increased lab productivity. With this technology, numerous samples can be analyzed in a short period, which is especially beneficial for time-sensitive applications. The infrared and micro-heating technology also ensures precise and uniform temperature control, delivering reliable and accurate measurement results.

Because time matters

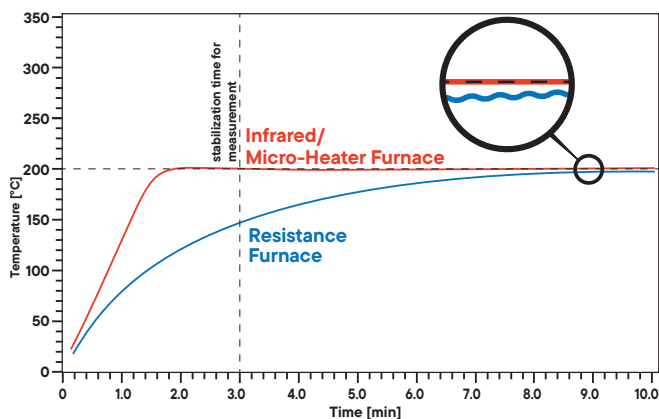

Comparison of time to reach the temperature stability. A high speed IR-micro-heater furnace reaches the set temperature much faster and delivers a superior isothermal temperature stability.

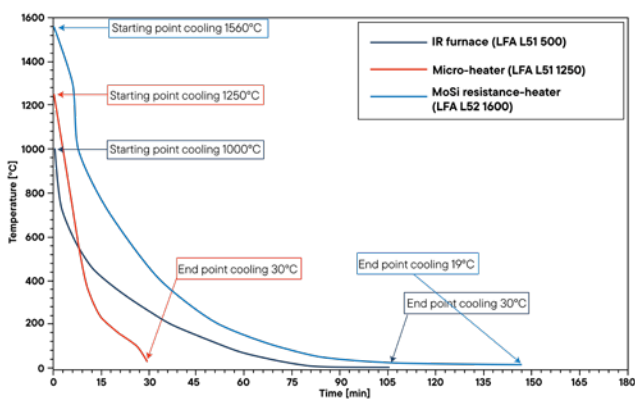

Cooling comparison of IR furnace, micro-heater, and MoSi resistance-heater clearly demonstrates the advantage of short cool-down times. This allows multiple measurements in quick succession and improves sample throughput. The IR furnace cools from 1000°C to 30°C in 105 minutes, while the micro-heater takes only ~26.5 minutes. Even when cooling from 1250°C, it stays below 30 minutes. The MoSi-heater, used for comparison, cools from 1560°C to 19°C in approximately 147 minutes.

LFA L51

LFA L51 500

This model offers cost-effective thermal conductivity, diffusivity, and specific heat measurements for up to 6 samples, with a temperature range of RT to 500°C and fast IR detection for precise analysis, making it ideal for applications involving polymers or low-melting-point materials.

LFA L51 1000

A modular instrument for thermal diffusivity and conductivity measurements, supporting temperatures from RT to 1000°C, optimized for quick measurement cycles and high flexibility, perfectly suited for analyzing ceramics and metals.

LFA L51 1250

Provides accurate measurements at temperatures up to 1250°C with rapid heating and cooling, making it well-suited for thermal analysis applications involving ceramics and metals.

LFA L51 LT

The low temperature version delivers precise measurements from -100 °C to 500 °C for various applications in the low temperature range.

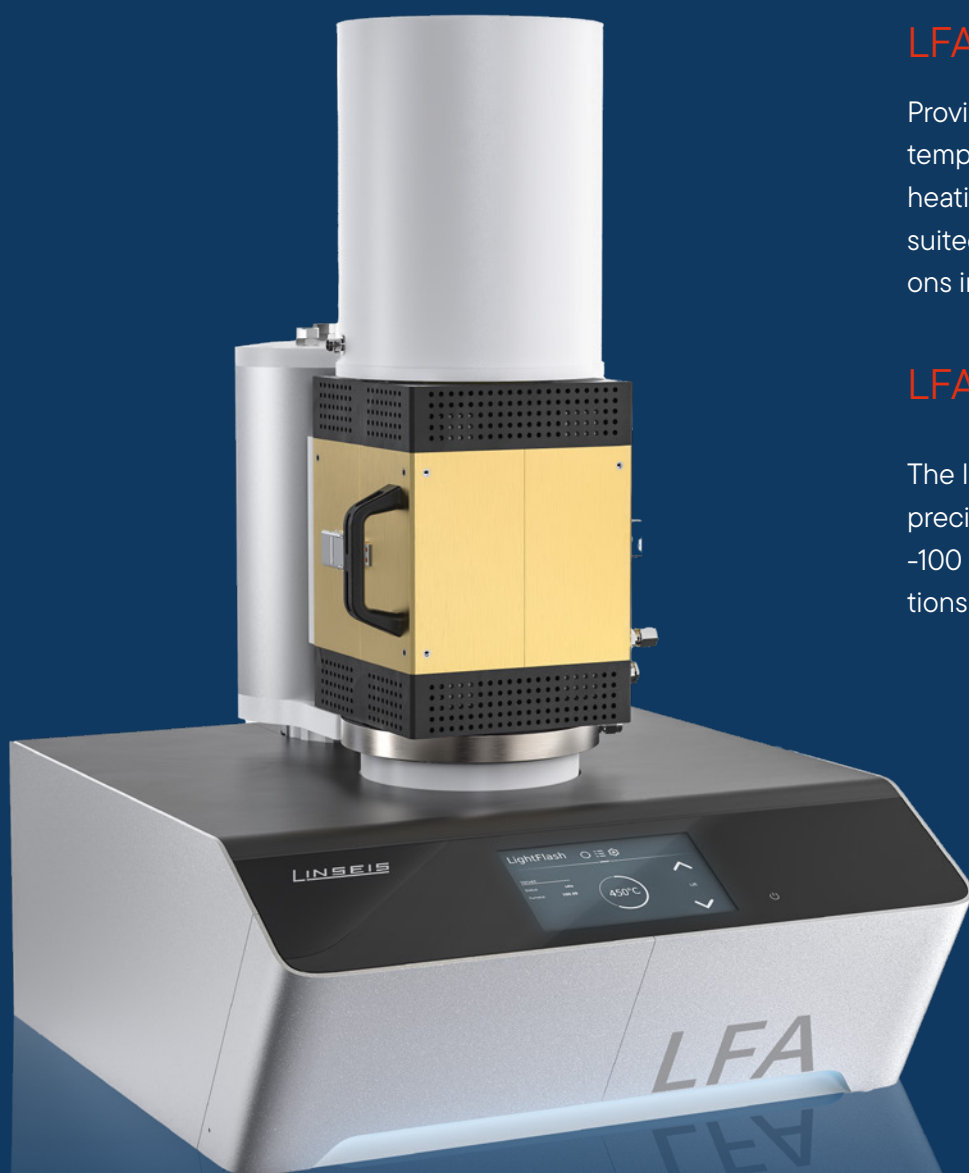

Unmatched sample throughput

Various sample holder types allow the measurement of a broad range of sample dimensions from 3 to 25.4 mm in solid, liquid, powder or paste form. In addition, sample carriers for phase change materials are available. The Linseis sample robot can measure up to 6 samples simultaneously, with options for up to 18 samples on request. Sample holder materials include graphite, SiC, alumina or various metals.

Sample carriers

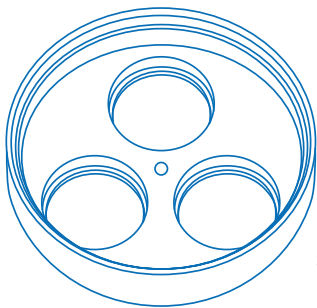

LFA LT/500/1000
3 round (25.4 mm) or
square (20 mm x 20 mm) samples

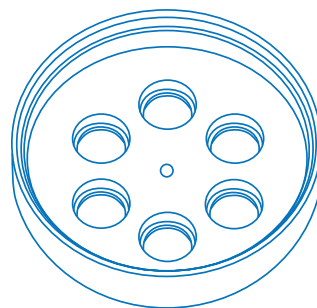

LFA LT/500/1000
6 round (3, 5, 6, 8, 10, 12.7 mm)
or square (3, 5, 6, 10 mm) samples

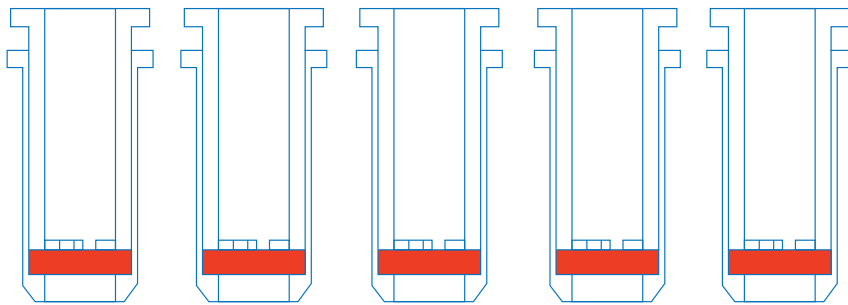

LFA L51 1250
5 samples
ø 10 mm or 12.7 mm, or 10 mm x 10 mm,
others on request

Sample holder

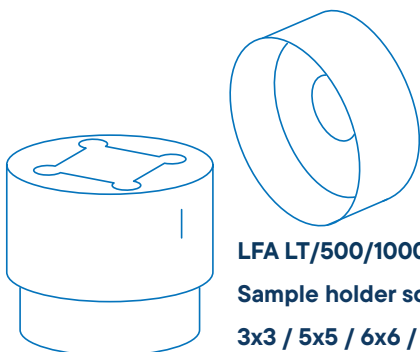

LFA LT/500/1000
Sample holder square
3x3 / 5x5 / 6x6 / 10x10 / 20x20 mm²

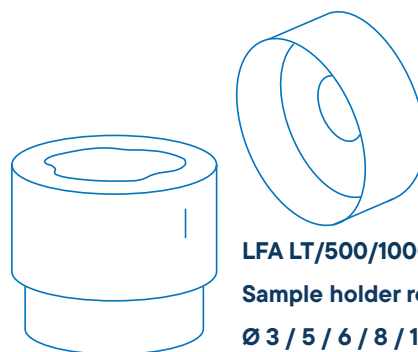

LFA LT/500/1000
Sample holder round
Ø 3 / 5 / 6 / 8 / 10 / 12.7 / 25.4 mm

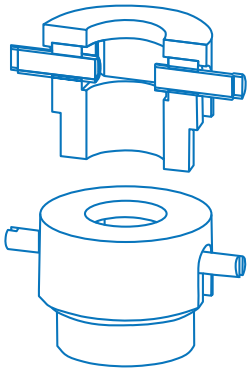

LFA LT/500/1000
Sample holder for lamellas
 Ø 10 mm x 10 mm

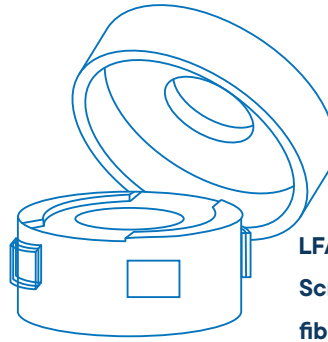

LFA LT/500/1000
Screwable sample holder for fibers and foils

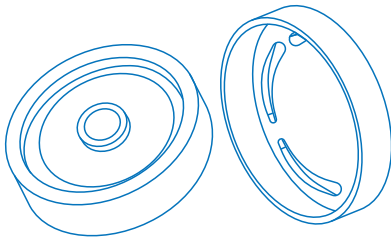

LFA LT/500/1000
In-plane e.g. thin films or anistropy
 Ø 12.7/ 25.4mm

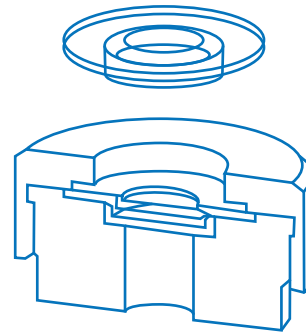

LFA LT/500/1000
Sample holder with sapphire crucible e.g. metal melt, molten salts
 Ø 12.7/ 25.4mm

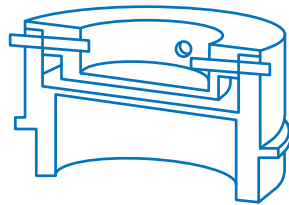
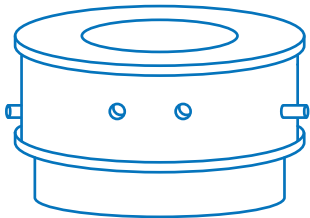

LFA LT/500/1000
Sample holder for liquids, powders, pastes and molten salts
 Ø 12.7mm, 25.4mm

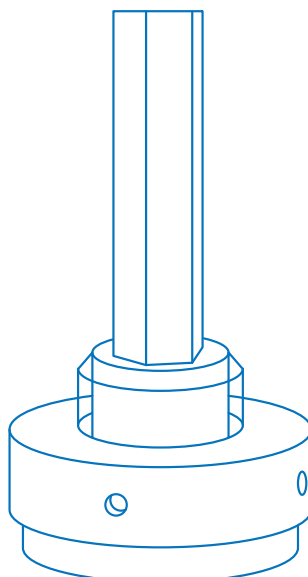
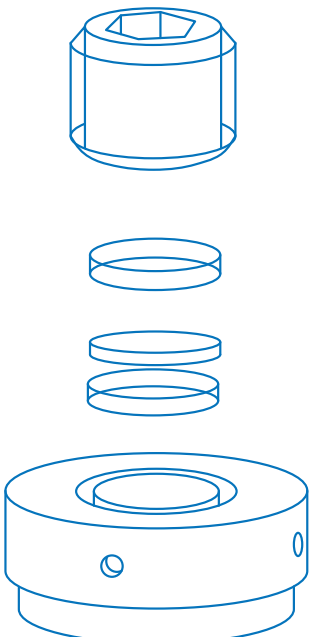

LFA LT/500/1000
Torque pressure container e.g. compressible samples
Torque: 0.3 up to 3 Nm
Sample: Ø 12.7 / 25.4 mm

deliv

outst

ser

ering

anding

vice



New features

Software Improvements

- **LINSEIS LiEAP Software:** Our completely new software platform is now even more focused on the needs of our customers to ensure that you are always informed of the latest status and receive support whenever it is needed.
- **Automatic updates and new features:** Our software receives regular automatic updates that not only improve security, but also continuously provide new features.
- **Lex Bus Plug & Play:** Our latest hardware interface Lex Bus revolutionizes the way data communicates within our systems. Lex Bus enables seamless and efficient integration of new hardware and software tools.
- **Improved furnace control:** Our new and further improved furnace control offers more precise temperature control, which leads to better measurement results and higher throughput through better temperature sequencing according to your wishes and requirements.
- **Preventive maintenance and problem detection:** Using intelligent components and accessories, our preventive maintenance approach detects problems and wear and tear before they can cause damage and keeps your device in top shape.

New improved light guiding system

Brings more energy to the sample and pushes the boundaries. The novel light guiding system significantly extends the measuring range by maximizing the power reaching the sample and leading to up to 3x stronger signals. This is particularly evident in samples exhibiting lower thermal conductivities or greater thickness, which are more easily and accurately measured.

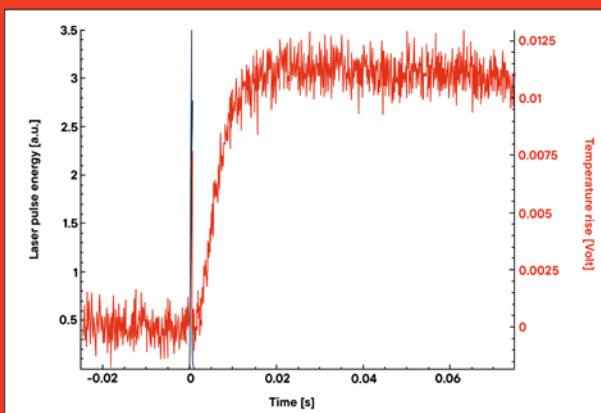

Measurement with conventional light guiding system*

*Multiple light guides are available for samples from 6 to 25.4 mm

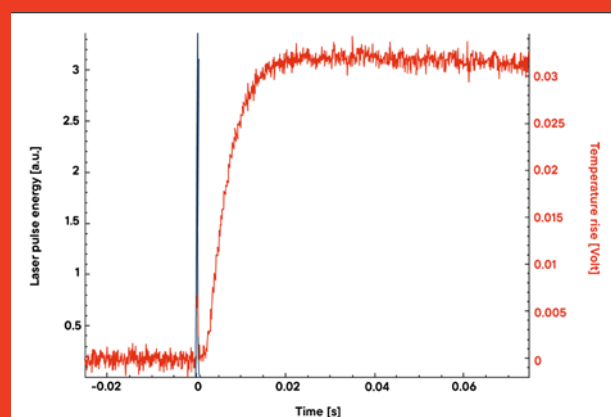

Measurement with new innovative glass tube*

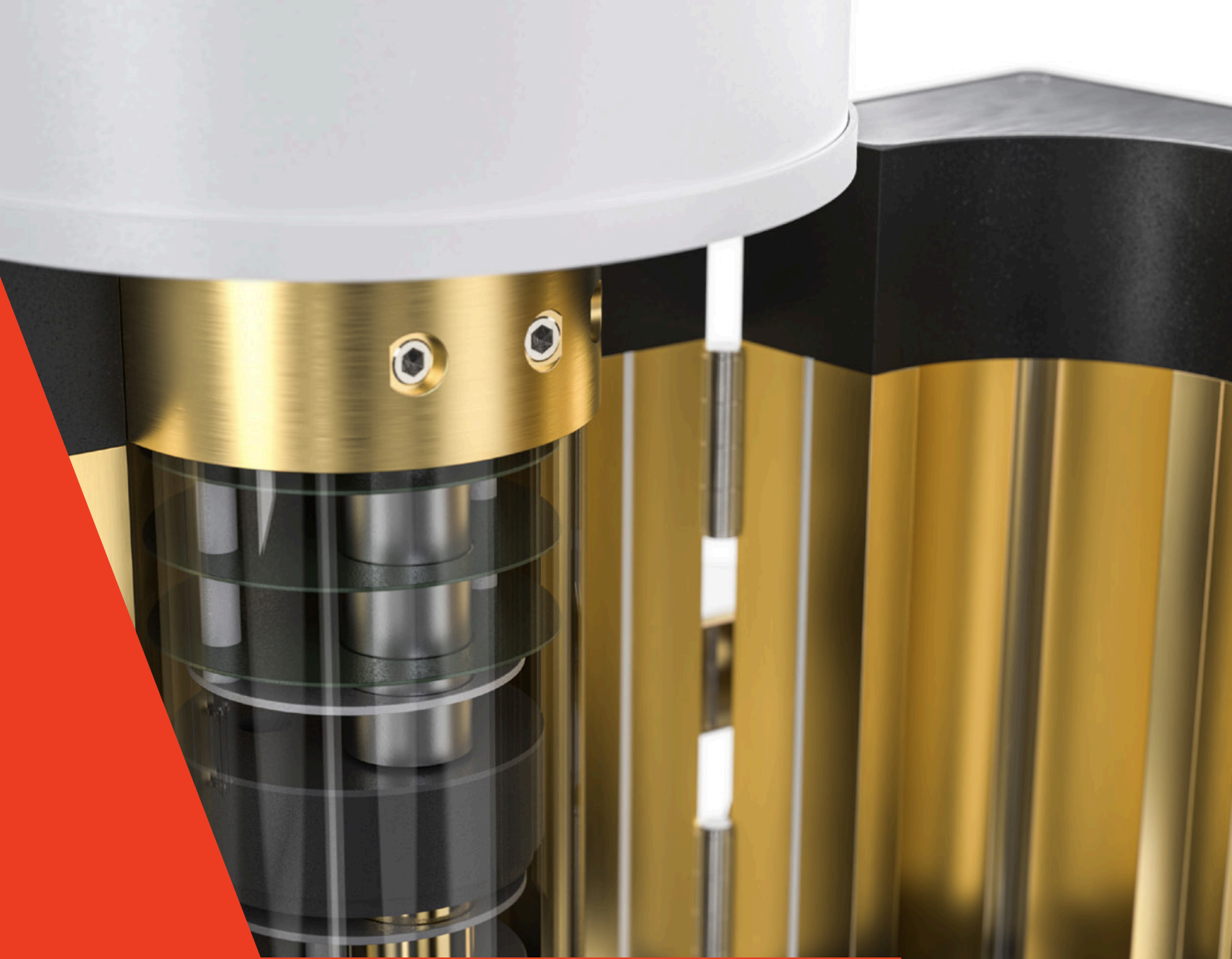

Linseis Lab Link

With Linseis Lab Link, we offer an integrated solution to address uncertainties in measurement results. With direct access to our application experts via the software, you can get advice on the correct measurement procedure and evaluation of results. This direct communication ensures optimal results and maximizes the efficiency of your measurements for precise analysis and research as well as a smooth process flow.

Design Improvements

The new device design is characterized by an elegant aluminum casing that is both robust and aesthetically pleasing. The LED status bar provides a user-friendly visualization of important information. A touch panel enables intuitive operation and contributes to a modern user experience that combines comfort and functionality. The new device design focuses on ergonomic operation.

New Hardware Features

PLH Upgrade: The LFA systems can be equipped with the PLH hardware, extending the measurement range to thin films down to tens of μm range.

Unique features

New Electronics

- **Enhanced Amplifier Electronics:** Upgraded electronics improve signal-to-noise (SNR) and 16-bit resolution, ensuring accurate and reproducible measurements for thin or conductive samples.
- **Higher Data Acquisition Rate:** A 2.5 MHz acquisition rate enables precise analysis of fast-conducting and thin materials, capturing detailed data in short timeframes.
- **Improved communication:** Either USB or Ethernet can be used to operate the Linseis equipment as stand alone or in a bigger network.

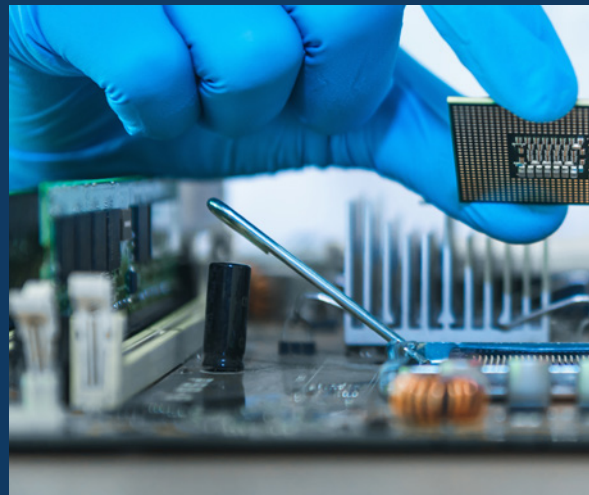

Complete Sample Illumination

The LFA L51 ensures full illumination of samples up to **25.4 mm** in diameter avoiding a radial temperature gradient in the sample. This results in improved reproducibility and more consistent results across a wide range of sample sizes.

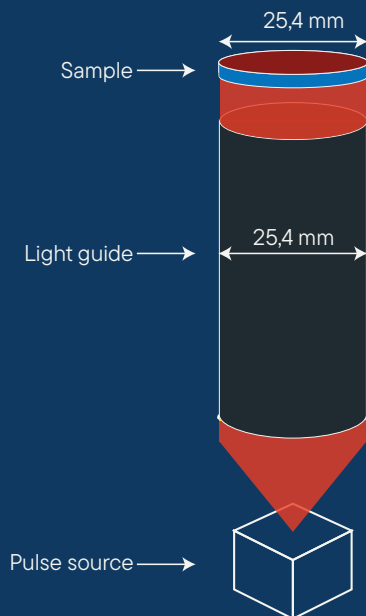

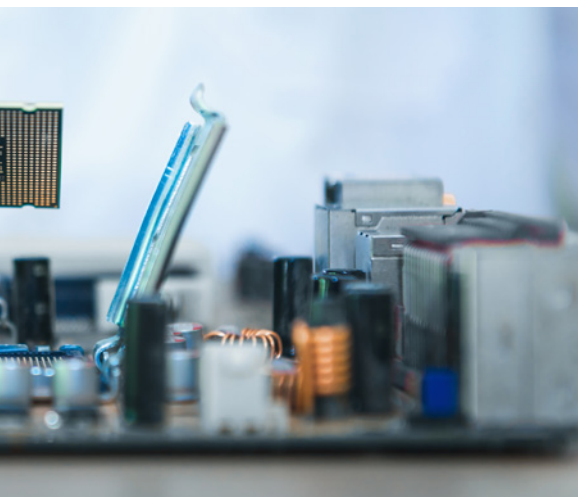

Optimized Low-Temperature Furnace

The newly introduced signal-optimized low-temperature furnace ensures gradient-free, high-accuracy measurements at lower temperatures and an increased speed for higher throughput.

Gradient-Free Hot Zone

The temperature control of the furnace is optimized with a gradient-free hot zone. This design ensures that the entire sample is subjected to uniform heating, leading to enhanced measurement reproducibility which is critical for accurate thermal conductivity results.



Peltier cooled detector

Two cooling options are available for IR detectors: a liquid nitrogen-cooled version and a thermoelectric (Peltier) cooled alternative. Although the Peltier-cooled detector has a slightly lower signal-to-noise ratio, it impresses with its high practicality. It is the ideal choice, especially in environments without access to liquid nitrogen, such as in protected areas like glove boxes.

External Electronics for Controlled Environments

The LFA can be integrated with external electronics for use in glove boxes or hot cells, allowing it to be used in controlled environments where sensitive materials or hazardous conditions may be present.

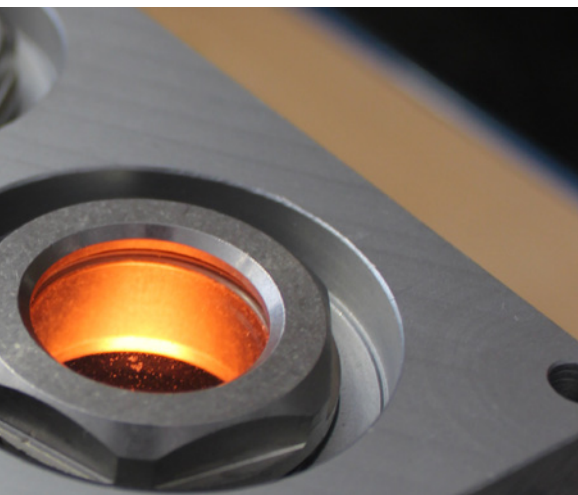

Software

ALL NEW LiEAP Software

The newly developed LiEAP software includes AI-based assistance that minimizes operator errors and reduces measurement uncertainties. Additionally, the software supports various unique models, including the Dusza model, which can handle transparent, porous, liquid, powder samples and multilayer systems.

- Fully compatible MS®Windows™ software
- Data security in case of power failure
- Safety Features (Thermocouple break protection, power failure, etc.)
- Online and offline Evaluation of current measurement
- Curve comparison
- Storage and export of evaluations
- Export and import of data in ASCII format
- Data export to MS Excel
- Multi - method analysis (DIL, STA, DSC, HCS, LSR, LZT, LFA)
- Programmable gas control
- **NEW workflow**

Evaluation Software

- Automatic or manual input of related measurement data: such as density and specific heat
- Universal combined evaluation model for data evaluation
- Special models for translucent or porous samples

Evaluation Models

- Dusza combined model
- **NEW McMasters model (for porous samples)**
- Parker
- Cowan 5 and 10
- Azumi
- Clark-Taylor
- Degiovanni
- Finite pulse correction
- Heat loss correction
- Baseline correction
- Multilayer model
- Determination of contact resistance
- Correction for translucent samples

Measurement Software

- Easy and user-friendly data input for temperature segments, gases etc.
- Controllable sample robot
- Software automatically displays corrected measurements after the energy pulse
- Fully automated measurement procedure for multi sample measurements
- Customer support
- Easy mode for efficient and fast measurements
- Expert mode for maximum individualisation
- Service model monitors the device mode and provides feedback

Cp (Specific Heat) determination by comparative method

To calculate the specific heat capacity, the maximum of the temperature rise in the sample is compared to the maximum of the temperature rise of a reference sample. Both, the unknown and the reference sample are measured under the same conditions **in a single run, using the sample robot**. So, the energy of the laser pulse and the sensitivity of the infrared detector can be assumed to be the same for both measurements. The temperature rise in the sample can be calculated according the following equation:

$$\Delta T = \frac{E}{m \cdot C_p}$$

ΔT = Rise in temperature [K]
 E = Pulse energy [J]
 m = Sample mass [g]
 C_p = Heat capacity [J/g·K]

By assuming the same energy for sample and reference, the Cp of the sample can be calculated according the following equation:

$$C_{p_{\text{sample}}} = \frac{C_{p_{\text{Reference}}} \cdot \Delta T_{\text{Reference}} \cdot m_{\text{Reference}}}{\Delta T_{\text{Sample}} \cdot m_{\text{Sample}}}$$

To achieve a good accuracy, the absorbability and emissivity of sample and reference must be the same (same coating), and the absolute heat capacity (Cp*sample mass) of sample and reference must be similar.

Pulse detection

In order to enhance the precision of the Cp measurement, it is essential to measure the energy of the pulse and the sensitivity of the detector, rather than assuming these to be constant.

Therefore, the updated LFA L51 offers the possibility to record the pulse shape and detects the pulse shape and perform an energy correction in the fully automated measurement cycle. This results in a highly accurate determination of the specific heat capacity in the comparative measurement mode with a known reference material.



Model selection

Supported model selection

The software allows the selection of various evaluation models. To support the user with the selection, the fit quality of all models can be easily displayed to guarantee an easy handling as well as maximum accuracy.

Empirical data from customers and Linseis application labs worldwide show that the combined Dusza model is the most universally applicable, typically providing the best fit between measurement data and model across a wide range of materials.

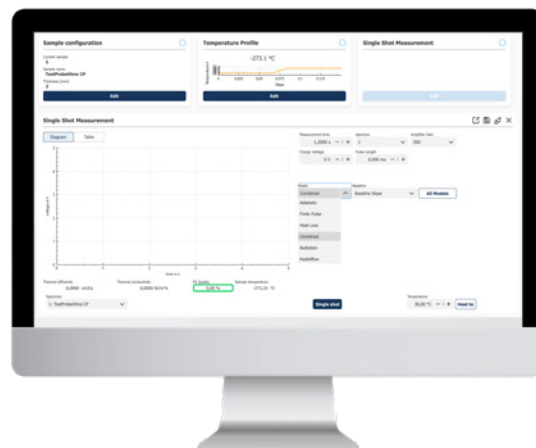

Combined Dusza-Model - Unique combined solution of the simultaneous heat loss and finite pulse corrections with the laser flash method

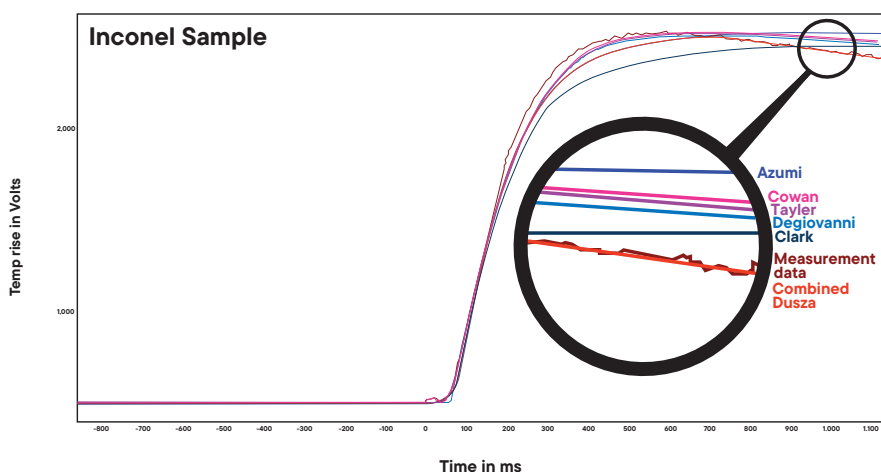

* Dusza, Laszlo. "Combined solution of the simultaneous heat loss and finite pulse corrections with the laser flash method." *High Temperatures-high Pressures (1995): 467-473.*

The universal combined model, based on Dusza's proven method, enables reliable evaluation of laser flash data by simultaneously correcting for heat losses, finite pulse effects, and non-adiabatic conditions. Thanks to non-linear parameter estimation, no manual model selection is needed—saving time and avoiding user error. Tested on over more than 100 samples, the method consistently delivers accurate and highest quality results. The example with an Inconel sample clearly shows: the combined model provides the best fit and highest precision compared to conventional approaches.

Low Thermal Conductive PMMA

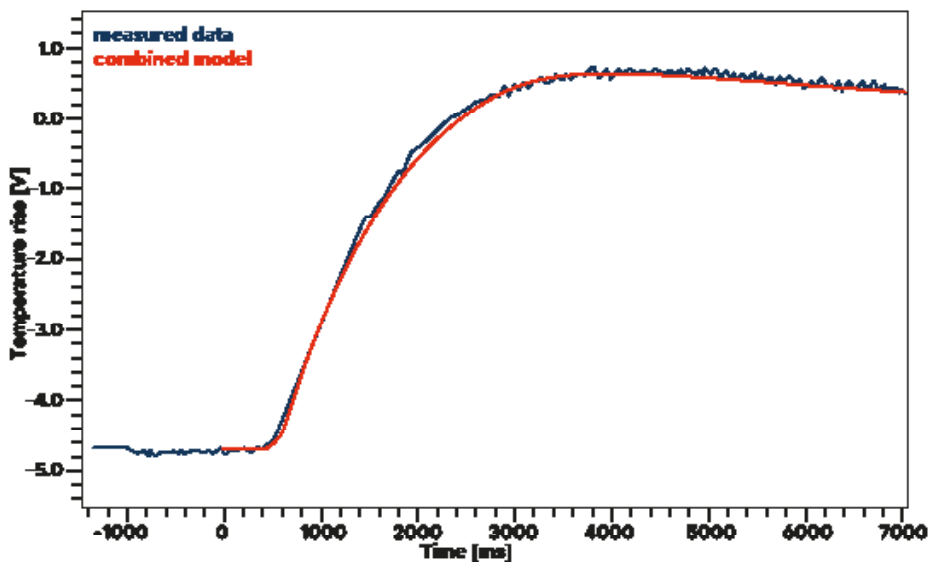

Temperature rise of the PMMA sample (length 1.01 mm, half time rise 1218.75 ms). The combined model illustrates a perfect fit to the data points

High Thermal Conductive Graphite

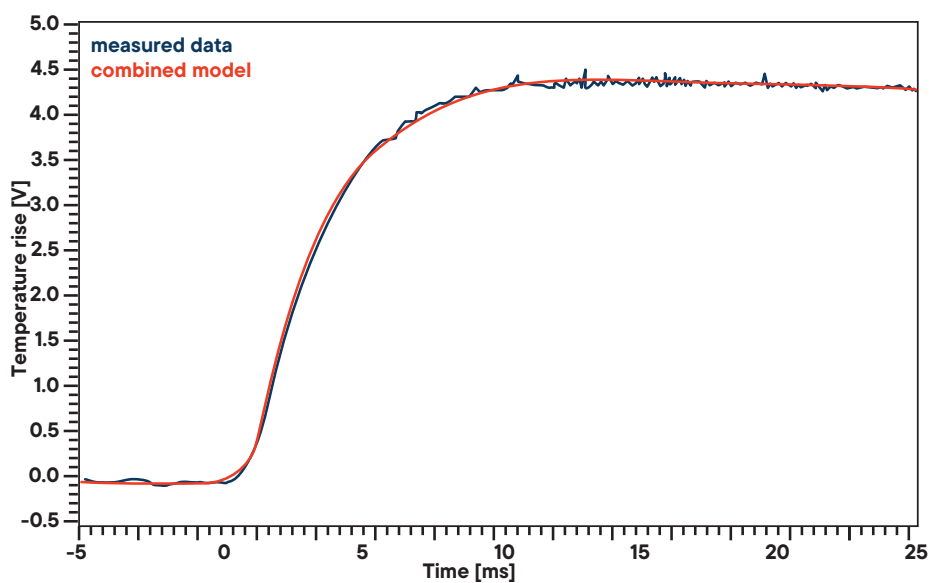

Temperature rise of a graphite sample (length 1.11 mm, half time rise 4.37 ms). The combined model curve is fitted to the data points.

Modified combined model / special model for translucent samples

Standard Heat Loss Model vs. Modified Model

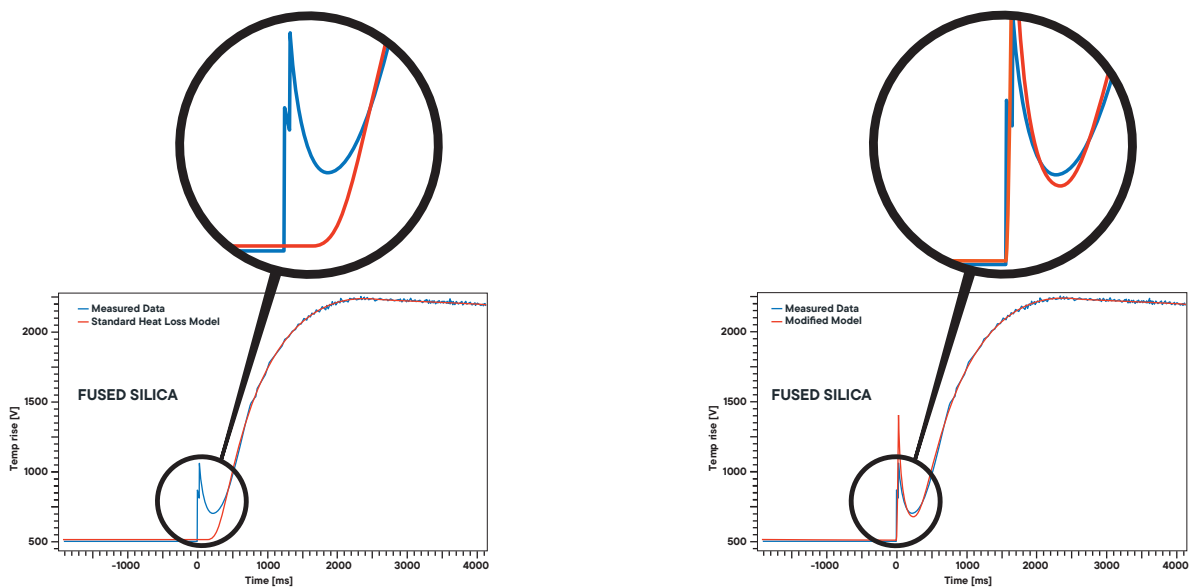

As illustrated in the graph, the temperature rise for translucent samples, generated by the induced energy pulse, results in an immediate signal increase of the detector. This initial signal has to be considered and corrected, as it distorts the measurement result to a seemingly higher thermal diffusivity. Up to now, existing models could not provide a sufficiently good fit for this immediate temperature rise phenomenon. Our unique combined model enables the correction of the sample data and provides an adjusted fit, leading to significantly improved measurement results.

McMasters Model for porous samples

The McMasters Model is a specialized tool designed to analyze heat transfer in porous materials with precision and flexibility.

Key Features:

- One-dimensional heat transfer model for accurate analysis.
- Includes finite penetration depth of the initial pulse as a key fit parameter.
- Accounts for heat losses at both front and rear surfaces of the sample.

This advanced model, based on the work of McMasters et al.,* ensures reliable and detailed results, making it an essential option for complex thermal investigations

* McMasters, Robert L. et al. "Accounting for Penetration of Laser Heating in Flash Thermal Diffusivity Experiments." *ASME. J. Heat transfer* (1999): 121(1): 15-21.

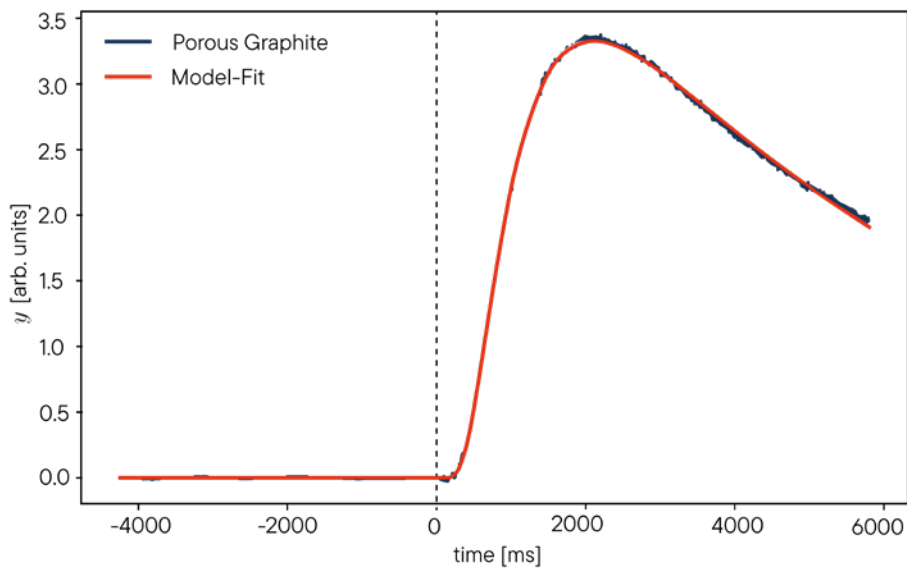

Technical Specifications

	LFA L51 LT/500/1000/1250
Temperature range	-100 up to 500 °C RT up to 500 / 1000 / 1250 °C *Boost function up to 1450 °C (limited furnace lifetime / LFA L51 1250)
Heating rate	0.01 up to 100 K/min
Cooling rate	max. 50 K/min (depends on model)
Thermal Diffusivity	0.01 up to 2000 mm ² /s
Thermal Conductivity	0.1 up to 4000 W/(m·K)
Accuracy	Thermal diffusivity ± 2.4 % Specific Heat ± 5 %
Repeatability	Thermal diffusivity ± 1.9 % Specific Heat ± 3 %
Flash source	Light flash 15 J/pulse variable pulse energy: software controlled Pulse width: 50 up to 2000 µs On request: 10 up to 1600 µs
IR-detector	InSb: ≥ RT MCT: -100 up to 500 °C
Atmosphere	Vacuum, inert, reducing, oxidizing
Vacuum	up to 10 ⁻³ mbar (2-stage rotary pump) up to 10 ⁻⁵ mbar (turbo molecular pump)
Data acquisition	2.5 MHz
Gas control	manual or MFC gas dosing systems
Sample holders	for round, square, powders, pastes, laminates, samples and mechanic pressure, thin films
Sample size	∅ 3/ 5/ 6/ 8/ 10/ 12.7/ 25.4 mm, or 3x3/ 5x5/ 6x6/ 10x10/ 20x20 mm ² (from 0.01 mm up to 6 mm height)
Sample numbers	up to 6 samples (18 on request) up to 5 samples (LFA500/1250)
Furhter options	PLH upgrade for thin film measurement, Separated electronics in protected environments



*pushing
boundaries*

Applications

LFA L51

LFA Overview



Thermal conductivity, thermal diffusivity and specific heat capacity of glass ceramics

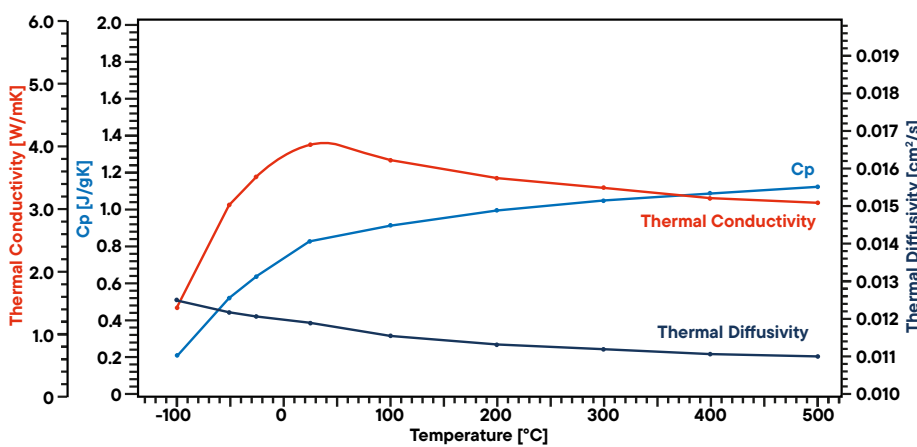

BCR 724, a standard glass ceramic has been measured using LFA L51 500 / 1000. Therefore, a small disc of 1mm thickness and 25.4mm diameter was cut out of a plate of bulk material and coated with graphite for the measurement. The LFA L51 gives the thermal diffusivity as a direct function of temperature. The Cp data was obtained in a comparative way by measuring a known ceramic standard under the same conditions in a second sample position of the same sample holder. Using this, the thermal conductivity was calculated out of the product of density, specific heat and thermal diffusivity. The result shows a slightly decreasing thermal diffusivity and conductivity while the Cp value increases over temperature.

Thermal conductivity of graphite

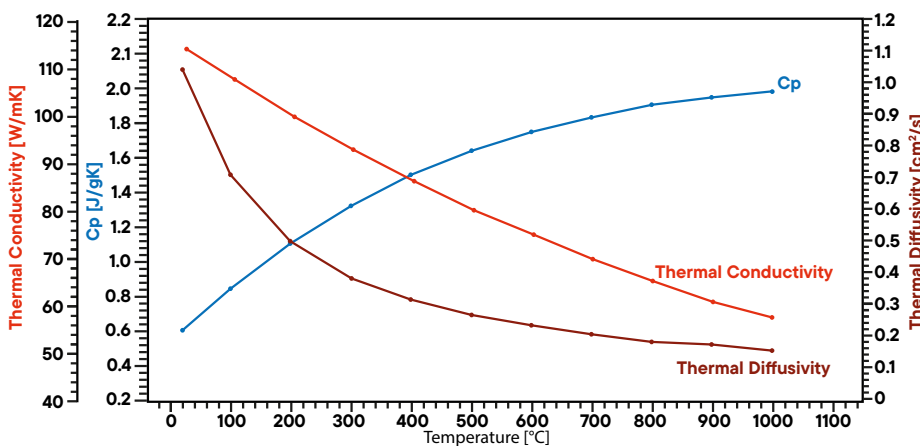

A graphite sample has been investigated using the LFA L51. Thermal diffusivity has been determined directly at several temperature between RT and 1000°C. Specific heat capacity has been determined using a known graphite standard in a second sample position as a reference in the same measurement. The product out of diffusivity, specific heat and density gives the corresponding thermal conductivity. The result shows a linear decreasing thermal conductivity which is typical and a thermal diffusivity that is showing a plateau above 500°C. The Cp is slightly increasing over temperature.

Thermal diffusivity of glass ceramic

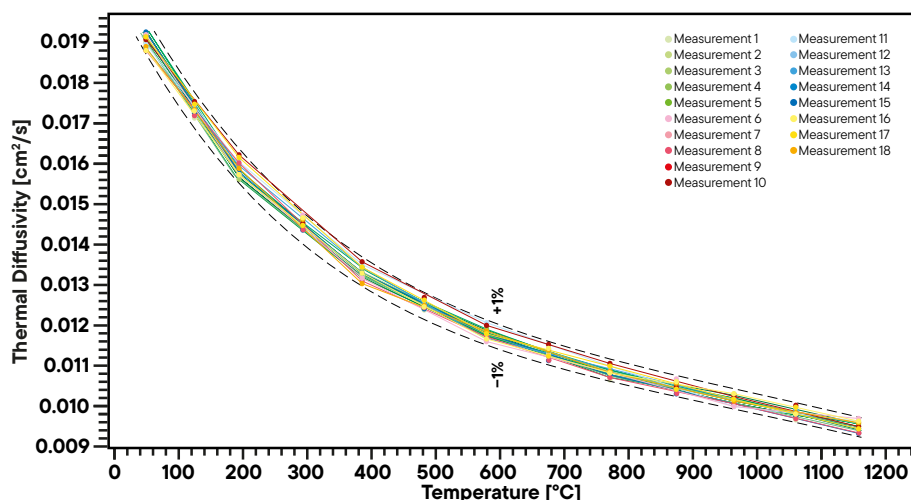

Pyroceram, a glass ceramic trademark of Corning used as a standard material in various applications, has been measured using the LFA L51 1250 to show the reproducibility of thermal diffusivity values. In total 18 measurements were performed with 18 samples that were cut out of one bulk block. Each sample was measured separately and the result shows a spread in the result that is in a range of +/- 1% in a temperature range up to 1160°C.

Thermal Conductivity of Polymers

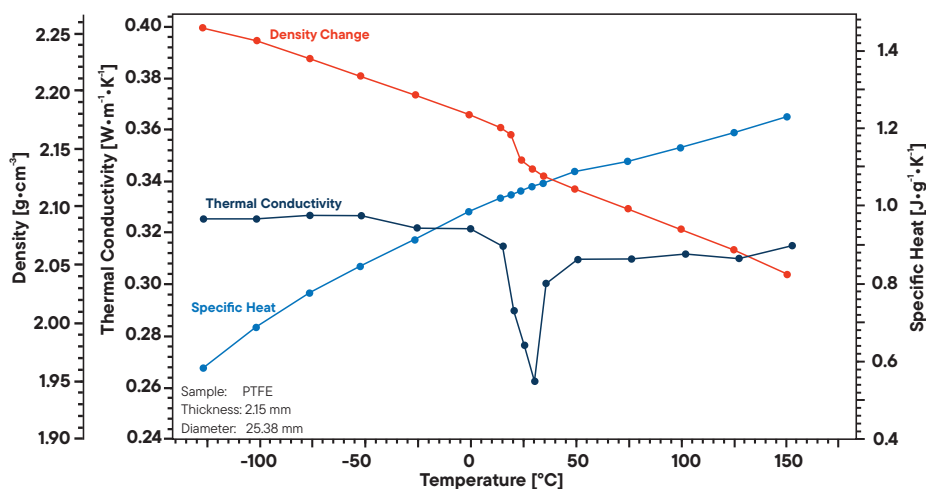

PTFE is a versatile material widely used in industries such as chemical processing and petrochemicals for applications like vessel linings, seals, gaskets, and washers due to its chemical inertness and corrosion resistance. In this study, a PTFE sample was measured using the LFA L51 500 up to 150°C in an inert atmosphere. Thermal conductivity was derived from specific heat and density change data recorded via dilatometer and DSC. The thermal conductivity remains stable across the temperature range, except around 30°C, where a solid-state phase transition occurs.



LINSEIS

pushing boundaries

LINSEIS GmbH Germany

Vielitzerstr. 43
95100 Selb

Tel.: (+49) 9287 880 0
E-mail: info@linseis.de

LINSEIS Inc. USA

109 North Gold Drive
Robbinsville, NJ 08691

Tel.: (+1) 609 223 2070
E-mail: info@linseis.com

LINSEIS China

Kaige Scientific Park
Room 120, Building T3, No.1220
Yuqiao Road, Pudong, Shanghai

Tel.: (+86) 61 90 12 03
Tel.: (+86) 50 55 06 42
E-mail: info@linseis.com.cn

LINSEIS India

Plot 65, 2nd Floor, Sai Enclave,
Sector 23, Dwarka05-800
110077 New Delhi

Tel.: +91-11-42883851
E-mail: sales@linseis.in



WWW.LINSEIS.COM